

D634-P Series
Direct Drive Proportional Valve
with Integrated 24 V Electronics
ISO 4401 Size 05

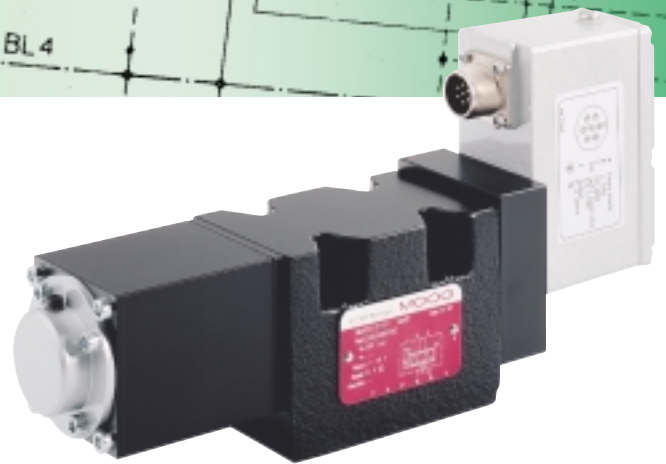

SECTION	PAGE	MOOG SERVO- AND PROPORTIONAL CONTROL VALVES
General	2	<p>For over 25 years, Moog has manufactured proportional control valves with integrated electronics. During this time more than 150,000 valves have been delivered. These servo control valves have been proven to provide reliable control for injection and blow molding equipment, die casting machines, presses, heavy industry equipment, paper and lumber processing and other applications.</p> <p>D634-P SERIES PROPORTIONAL CONTROL VALVES</p> <p>The D634-P Series are Direct Drive Valves (DDV) with electric closed loop spool position control.</p> <p>These valves are throttle valves for 3-, 4-, and 2x2-way applications. They are suitable for electrohydraulic position, velocity, pressure and force control systems including those with high dynamic response requirements.</p> <p>The spool drive device is a permanent magnet linear force motor which can actively stroke the spool from its spring centered position in both directions. This is an advantage compared with proportional solenoids with one force direction only. The closed loop spool position electronics and pulse width modulated (PWM) drive electronics are integrated into the valve.</p> <p>The integrated electronics of the valves is a new development featuring SMD technology with pulse width modulated (PWM) current output stage and requires a 24 VDC power supply.</p>
Features and Benefits	3	
General Technical Data, Symbols	4	
Electronics	5	
Technical Data	7	
Ordering Information	10	
Notes	11	

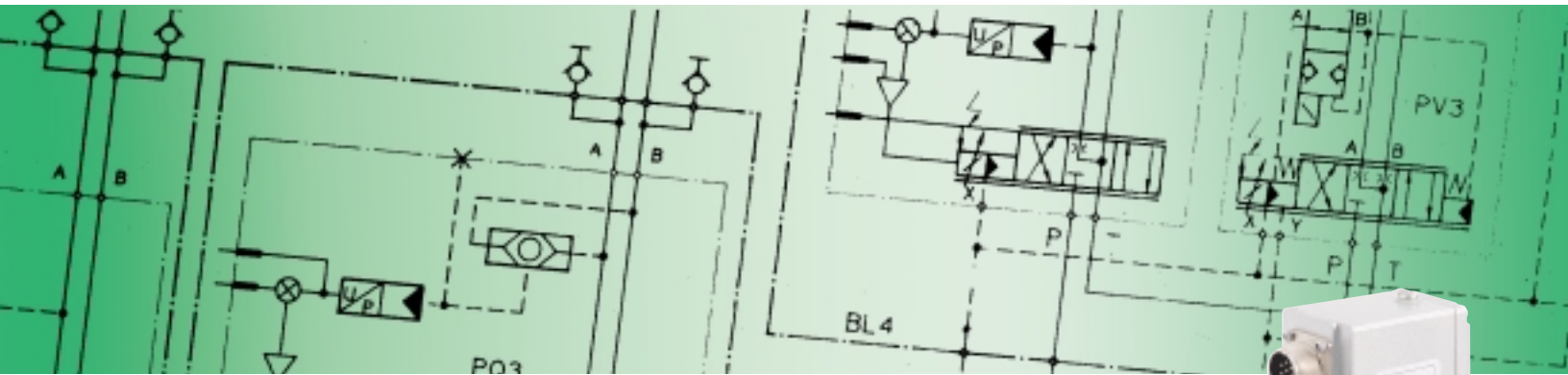

The valve series described in this catalog have successfully passed EMC tests required by EC Directive. Please refer to the respective references in the electronics section.

NOTICE

- Before installation of the valve into the system the complete hydraulic system must be flushed.
- Please read the notes in section "Electronics", page 6.

This catalog is for users with technical knowledge. To ensure that all necessary characteristics for function and safety of the system are given, the user must check the suitability of the products described herein. In case of doubt, please contact Moog.

Our quality management system conforms to DIN EN ISO 9001.

BENEFITS OF DIRECT DRIVE SERVO VALVES (DDV)

- ❑ Directly driven by a permanent magnet linear force motor with high force level
- ❑ No pilot oil flow required
- ❑ Pressure independent dynamic performance
- ❑ Low hysteresis and low threshold
- ❑ Low current consumption at and near hydraulic null
- ❑ Increased operation limits (at high pressure drops)
- ❑ Standardized spool position monitoring signal with low residual ripple
- ❑ Electric null adjust
- ❑ With loss of supply voltage, a broken cable and emergency stop, the spool returns to its spring centered position without passing a load move position.

DIRECT DRIVEN PROPORTIONAL VALVE (DDV) OPERATING PRINCIPLE

The position control loop for the spool with position transducer and linear force motor is closed by the integrated electronics. An electric signal corresponding to the desired spool position is applied to the integrated electronics and produces a pulse width modulated (PWM) current to drive the linear force motor. An oscillator excites the spool position transducer (LVDT) producing an electric signal proportional to spool position.

The demodulated spool position signal is compared with the command signal, and the resulting spool position error causes current in the force motor coil until the spool has moved to its commanded position, and the spool position error is reduced to zero. The resulting spool position is thus proportional to the command signal.

D634-P Series single stage Proportional Valve

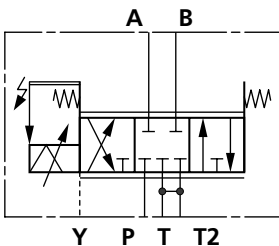

Hydraulic symbol:

Symbol shown with electric supply on and zero command signal.

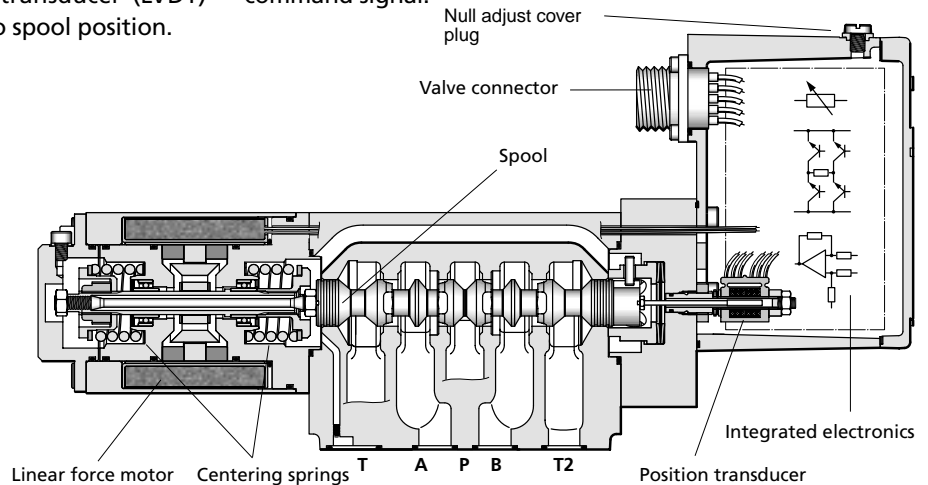

PERMANENT MAGNET LINEAR FORCE MOTOR OPERATION

The linear force motor is a permanent magnet differential motor. The permanent magnets provide part of the required magnetic force. For the linear force motor, the current needed is considerably lower than would be required for a comparable proportional solenoid. The linear force motor has a neutral mid-position from which it generates force and stroke in both directions. Force and stroke are proportional to current.

High spring stiffness and resulting centering force plus external forces (i.e. flow forces, friction forces due to contamination) must be overcome during out-stroking. During backstroking to center position, the spring force adds to the motor force and provides additional spool driving force which makes the valve much less contamination sensitive. The linear force motor needs very low current in the spring centered position.

Proportional solenoid systems require two solenoids with more cabling for the same function. Another solution uses a single solenoid, working against a spring. In case of current loss in the solenoid, the spring drives the spool to the end position by passing through a fully open position. This can lead to uncontrolled load movements.

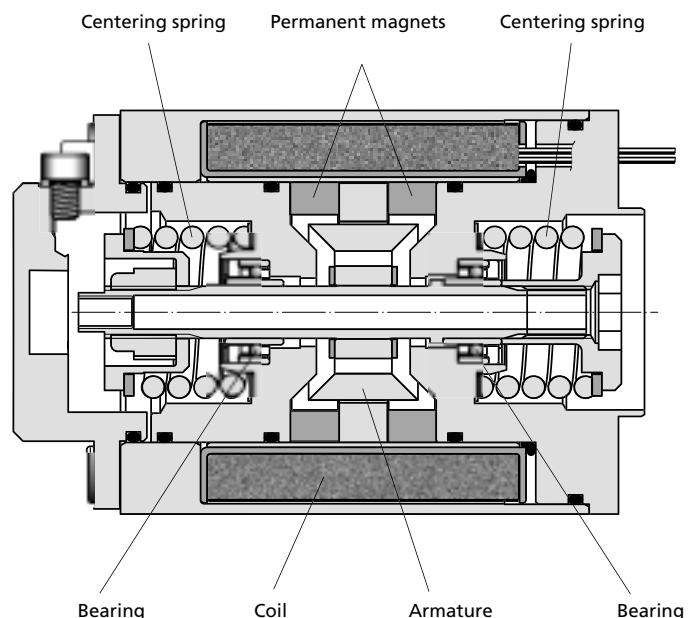

PERFORMANCE SPECIFICATIONS FOR STANDARD MODELS

Operating pressure range

Ports P, A and B up to 350 bar (5000 psi)
Port T up to 210 bar (3000 psi)

Temperature range

Ambient -20 °C to +60 °C
(-4 °F to +140 °F)

Fluid -20 °C to +80 °C
(-4 °F to +170 °F)

Seal material

Operating fluid FPM, others on request
mineral oil based hydraulic fluid (DIN 51524, part 1 to 3), others on request

Viscosity recommended 15 to 100 mm²/s (cSt)
allowed 5 to 400 mm²/s (cSt)

System filtration

High pressure filter (without bypass, but with dirt alarm) mounted in the main flow and if possible directly upstream of the valve.

Class of cleanliness

The cleanliness of the hydraulic fluid affects the performance (spool positioning, high resolution) and wear (metering edges, pressure gain, leakage) of the proportional valve.

Recommended cleanliness class

For normal operation ISO 4406 < 15 / 12
For longer life (wear) ISO 4406 < 14 / 11

Filter rating recommended

For normal operation $\beta_{10} \geq 75$ (10 µm absolute)
For longer life (wear) $\beta_6 \geq 75$ (6 µm absolute)

Installation options

any position,
fixed or movable

Vibration

30 g, 3 axes

Degree of protection

EN60529: class IP 65 with mating connector mounted

Shipping plate

Delivered with an oil sealed shipping plate

4-WAY FUNCTION

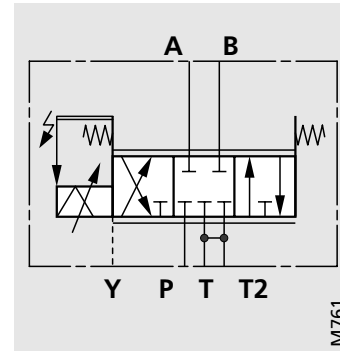

4-way version
spring centered

- Flow control (throttle valve) in port A and port B
- Port Y required if pressure $p_T > 50$ bar (715 psi) in port T
- for 3-way function close port A or port B of the manifold
- Spools with ~ axis cut or 10 % overlap available

2X2-WAY FUNCTION

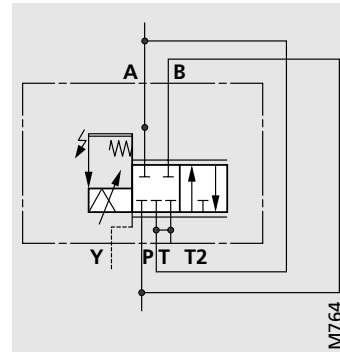

2x2-way version
(Y-Port required)

- Flow control (throttle valve) in port A
- Port Y required
- Connect externally port P with port B, and port A with port T

VALVE FLOW CALCULATIONS

The actual valve flow is dependent on the spool position and the pressure drop across the spool lands.

At 100% command signal (i.e. +10 VDC = 100% valve opening) the valve flow at rated pressure drop $\Delta p_N = 35$ bar (500 psi) per metering land is the rated flow Q_N . For other than rated pressure drop, the valve flow changes at constant command signal according to the square root function for sharp edged orifices.

$$Q = Q_N \cdot \sqrt{\frac{\Delta p}{\Delta p_N}}$$

Q / l/min = calculated flow
 Q_N / l/min = rated flow
 Δp / bar = actual valve pressure drop
 Δp_N / bar = rated valve pressure drop

The actual valve flow Q calculated in this way should result in an average flow velocity in ports P, A, B or T of less than 30 m/s.

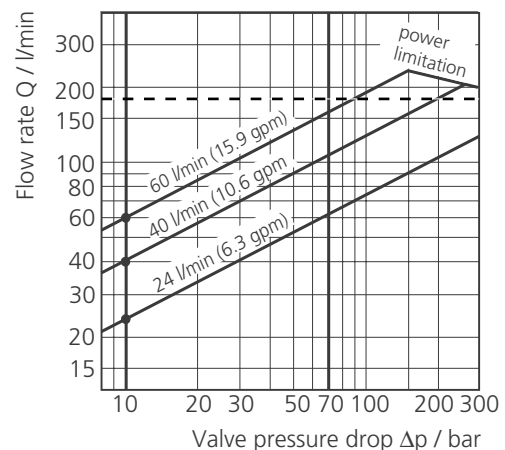

--- recommended flow rate limit
 $Q = 180$ l/min (47 gpm)

GENERAL REQUIREMENTS FOR VALVE ELECTRONICS

- ❑ Supply 24 V DC, min. 19 V DC, max. 32 V DC
Current consumption I_{Amax} : 2.2 A
External fuse per valve : 2.5 A (slow)
- ❑ All signal lines, also those of external transducers, shielded.
- ❑ Shielding connected radially to \perp (0 V), power supply side, and connected to the mating connector housing (EMC).
- ❑ **EMC:** Meets the requirements of emission: EN55011:1998+A1:1999 (limit class: B) and immunity: EN61000-6-2:1999
- ❑ Minimum cross-section of all leads $\geq 0.75 \text{ mm}^2$ (0.001 in²). Consider voltage losses between cabinet and valve.
- ❑ **Note:** When making electric connections to the valve (shield, protective earth) appropriate measures must be taken to ensure that locally different earth potentials do not result in excessive ground currents. See also Moog Application Note TN 353.

VALVE ELECTRONICS WITH 24 VOLT SUPPLY VOLTAGE AND 6+PE POLE CONNECTOR

**Command signal 0 to ±10 mA floating,
Valves with current command input**

The spool stroke of the valve is proportional to $I_D = -I_E$.
100 % valve opening P → A and B → T is achieved at $I_D = +10$ mA. At 0 mA command the spool is in centered position. The input pins D and E are inverting. Either pin D or E is used according to the required operating direction. The other pin is connected to signal ground at cabinet side.

**Command signal 0 to ±10 V,
Valves with voltage command input**

The spool stroke of the valve is proportional to $(U_D - U_E)$.
100 % valve opening P → A and B → T is achieved at $(U_D - U_E) = +10$ V.
At 0 V command the spool is in centered position. The input stage is a differential amplifier. If only one command signal is available, pin D or E is connected to signal ground at cabinet side, according to the required operating direction.

Actual value 4 to 20 mA

The actual spool position value can be measured at pin F (see diagram below). This signal can be used for monitoring and fault detection purposes.

The spool stroke range corresponds to 4 to 20 mA.
The centered position is at 12 mA. 20 mA corresponds to 100 % valve opening P → A and B → T. The position signal output 4 to 20 mA allows detecting a cable break when $I_F = 0$ mA.

**Circuit diagram for measurement of actual value I_F
(position of spool) for valves with 6+PE pole connector**

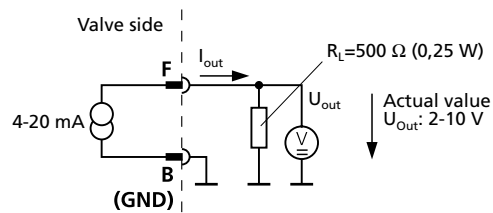

The position signal output 4 to 20 mA allows detection of a cable break when $I_F = 0$ mA.
For failure detection purposes it is advised to connect pin F of the mating connector and route this signal to the control cabinet.

WIRING FOR VALVES WITH 6+PE POLE CONNECTOR

To EN 175201 Part 804¹⁾, and mating connector (type R and S, metal shell) with leading protective earth connection (\perp).
See also Application Note AM 426 E.

Pin	Function	Current command 0 to ± 10 mA floating	Voltage command 0 to ± 10 V DC
A	Supply	24 V DC (19 to 32 V DC)	
B	Supply / Signal ground	⊥ (0 V)	
C	not used		
D	Input rated command (differential)	Input command $I_D = - I_E$: 0 to ± 10 mA	$U_{D-E} = 0$ to ± 10 V $R_e = 10$ KΩ
E		Input command (inv.) $I_E = - I_D$: 0 to ± 10 mA ($R_e = 200$ Ω)	
F	Output actual valve spool position	Input voltage U_{D-B} and U_{E-B} for both signal types is limited to min. -15 V, max. +24 V. $I_{F-B} = 4$ to 20 mA. At 12 mA spool is in centered position. $R_L = 300$ to 500 Ω	
\perp PE	Protective earth		

¹⁾ formerly DIN 43563

PERFORMANCE SPECIFICATIONS FOR STANDARD MODELS

Model . . . Type		D634
Mounting pattern with or without leakage port Y ³⁾		ISO 4401-05-05-0-94
Port diameter	mm (in)	11.5 (0.45)
Valve version ²⁾		Single stage, spool in bushing 3-way, 4-way, 2x2-way
Spool actuation		directly, with permanent magnet linear force motor
Pilot supply		none
Mass	kg (lb)	7.3 (16.1)
Rated flow ($\pm 10\%$) at $\Delta p_N = 5$ bar (75 psi) per land	l/min (gpm)	24 / 40 / 60 (6.3 / 10.6 / 15.8)
Max. valve flow	l/min (gpm)	185 (48.8)
Operating pressure max.		
Ports P, A, B	bar (psi)	350 (5000)
Port T without Y	bar (psi)	50 (715)
Port T with Y	bar (psi)	210 (3000)
Port Y	bar (psi)	directly to tank
Response time for 0 to 100% stroke, typical	ms	≤ 25
Threshold ¹⁾	%	< 0.1
Hysteresis ¹⁾	%	< 0.2
Null shift ¹⁾ with $\Delta T = 55$ K	%	< 1.5
Null leakage flow ¹⁾ max. (axis cut)	l/min (gpm)	1.2 / 2.0 / 3.0 (0.32 / 0.53 / 0.79)

- 1) At operating pressure $p_p = 140$ bar (2000 psi), fluid viscosity of $32 \text{ mm}^2/\text{s}$ ($0.05 \text{ in}^2/\text{s}$) and fluid temperature of $40 \text{ }^\circ\text{C}$ ($104 \text{ }^\circ\text{F}$)
- 2) See symbols page 4
- 3) Leakage port Y must be used
 - with 3- and 4-way function and $p_T > 50$ bar (715 psi)
 - with 2x2-way function

CHARACTERISTIC CURVES (TYPICAL)

Step response

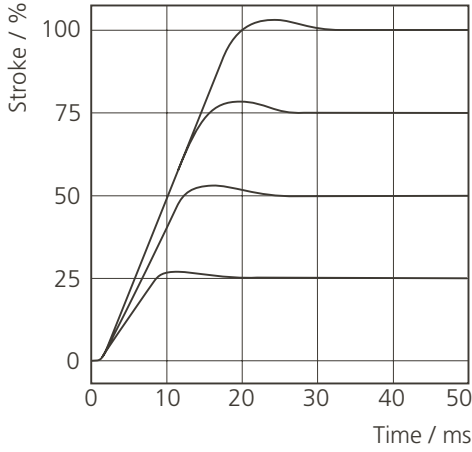

Flow signal characteristic curve

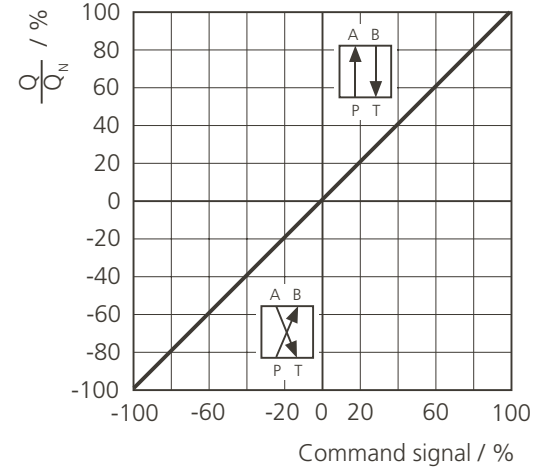

Frequency response

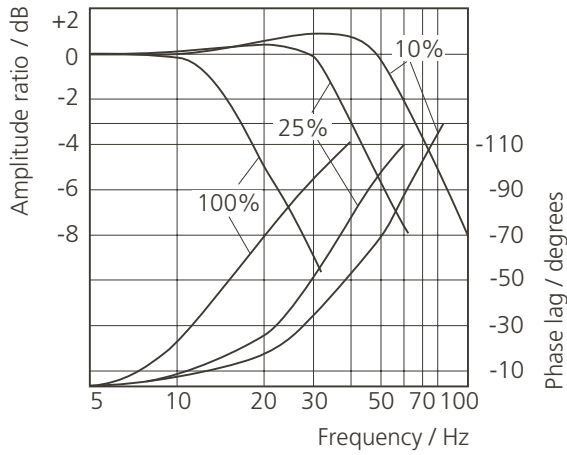

Pressure signal characteristic curve

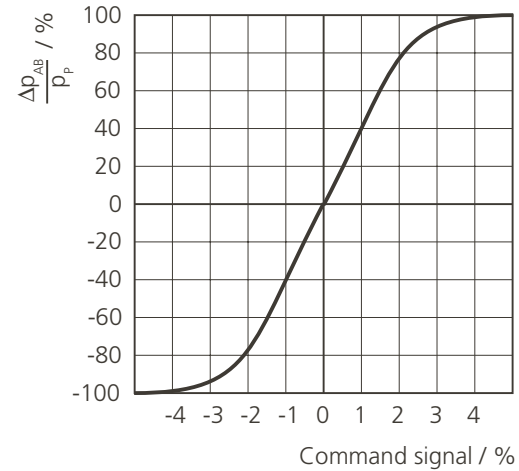

Valve flow diagram

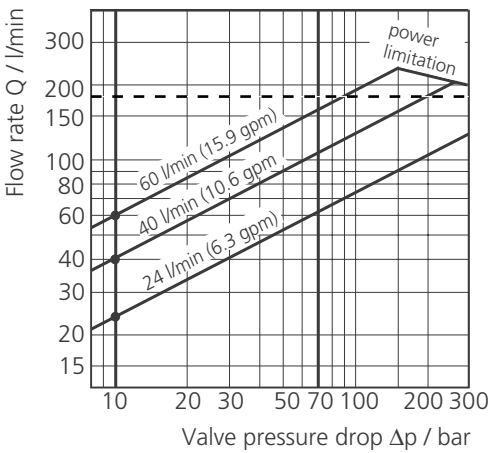

-----: recommended flow rate limit
 $Q = 180 \text{ l/min (47 gpm)}$

INSTALLATION DRAWING

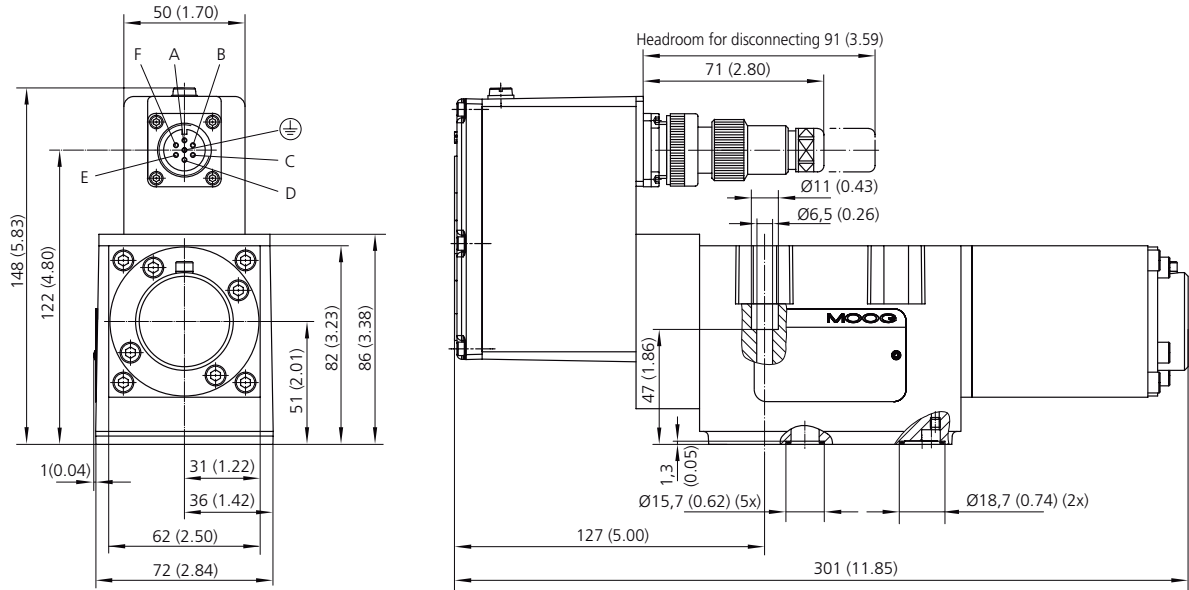

Mounting pattern

ISO 4401-03-03-0-94, without X port

mm

	P	A	B	T	T ₂	X ¹⁾	Y	F ₁	F ₂	F ₃	F ₄
	Ø11.2	Ø11.2	Ø11.2	Ø11.2	Ø11.2		Ø 6.3	M6	M6	M6	M6
x	27	16.7	37.3	3.2	50.8		62	0	54	54	0
y	6.3	21.4	21.4	32.5	32.5		11	0	0	46	46

inch

	P	A	B	T	T ₂	X ¹⁾	Y	F ₁	F ₂	F ₃	F ₄
	Ø0.44	Ø0.44	Ø0.44	Ø0.44	Ø0.44		Ø0,25	M6	M6	M6	M6
x	1.06	0.66	1.47	0.13	2.00		2.44	0	2.13	2.13	0
y	0.25	0.84	0.84	1.28	1.28		0.43	0	0	1.81	1.81

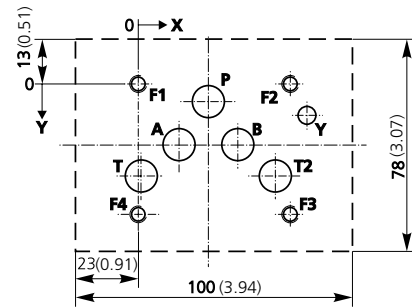

¹⁾ Port X must not be drilled, not sealed at valve base.

Mounting surface needs to be flat within 0.01 mm (0.0004 inch) over a distance of 100 mm (3.94 inch). Average surface finish value, Ra = 0.8 µm.

Spare parts and Accessories

O-Rings (included in delivery) for ports P,T,T ₂ ,A,B for port Y	5 pieces ID 12.4 x Ø 1.8 (ID 0.49 x Ø 0.07) 1 piece ID 15.6 x Ø 1.8 (ID 0.61 x Ø 0.07)	NBR 90 Shore 45122-004 45122-011	FPM 90 Shore 42082-004 42082-011
Mating connector, waterproof IP65 (not included in delivery) 6+PE-pole	B97007-061	EN 175201 Part 804	for cable dia min. Ø 10 mm (0.394 in), max. Ø 12 mm (0.472 in)
Flushing plates	for P,A,B,T,T ₂ ,X,Y B67728-001		
Flushing plates	for P,A,B,T,T ₂ ,X,Y B67728-002		
Flushing plates	for P,A,B,T,T ₂ ,X,Y B67728-003		
Mounting manifolds	on request		
Mounting bolts (not included in delivery) M 6 x 60 DIN EN ISO 4762-10.9	A03665-060-060	required torque 13 Nm (115 inch pounds)	required 4 pieces

ORDERING INFORMATION

Model-Number				Type designation											
D 63 4											
Series				Supply voltage											
4 Size 05				2 24 V DC (19 to 32 V DC)											
Specification-Status				Signals for 100% spool stroke ¹⁾											
- Series specification				Command Output											
E Preseries specification				M ±10 V DC + 4 to + 20 mA											
Z Special specification				X ±10 mA, floating + 4 to + 20 mA											
Model designation				deadband compensation on request											
assigned at the factory				Valve connector											
Factory identification				S 6+PE pole EN 175201 Part 804											
Valve version				Seal material											
P with integrated electronics; spool in body				V FPM (Viton)											
Rated flow				N NBR (Buna), others on request											
Q _N / l/min at Δp _N = 35 bar Δp _N = 5 bar per land Series (Q _N / gpm at Δp _N = 500 psi) (Δp _N = 75 psi per land)				Y-port											
24 60 (15.9) 24 (6.3) D634 - P				0 closed with plug p _{Tmax} = 50 bar (715 psi)											
40 100 (26.3) 40 (10.6) D634 - P				3 open, with filter insert p _T > 50 bar (715 psi)											
60 160 (42.3) 60 (15.9) D634 - P				Spool position without electric supply											
Maximum operating pressure				M mid position											
K 350 bar (5000 psi)				F P ↗ B, A ↘ T connected (10% open)											
Bushing / Spool type				D P ↗ A, B ↘ T connected (10% open)											
A 4-Way: ~ axis cut, linear characteristic				other openings on request											
D 4-Way: 10% overlap, linear characteristic				Linear motor											
Z 2x2-Way: P ↗ A, B ↘ T, with Y-port only				6 Standard											
X Special spool on request															

Options may increase price and delivery.
 All combinations may not be available.
 Preferred configurations are highlighted.
 Technical changes are reserved.

¹⁾ input voltage limited, see page 6



Argentina
Australia
Austria
Brazil
China
Finland
France
Germany
India

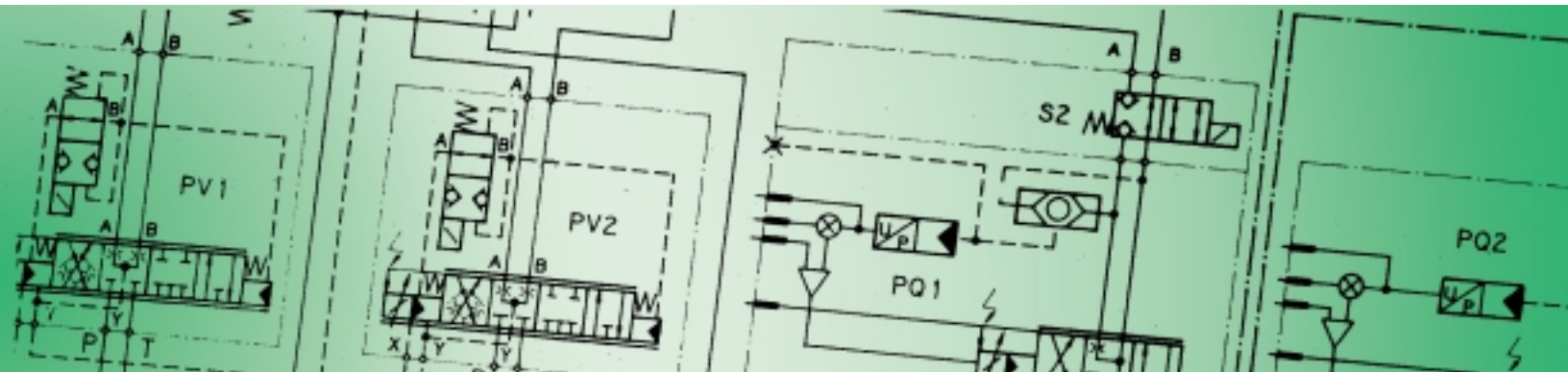

Ireland
Italy
Japan
Korea
Luxembourg
Norway
Russia
Singapore
Spain
Sweden
United Kingdom
USA

MOOG
Industrial Controls Division

Moog Inc., East Aurora, NY 14052-0018
Telephone: 716/655-3000
Fax: 716/655-1803
Toll Free: 1-800-272-MOOG
www.moog.com