

## **DDV** *Direct Drive Valve* Pressure Control Valve with integrated Electronics Cetop 3 · Series D 635

### General

The series D635 is a direct driven pressure control valve (PCV) of size NG 6 (Cetop 3). The PCV consists of a DDV servovalve, pressure control electronics, pressure sensor and ramp circuit for the pressure command signal. All elements are integrated in a compact unit. This provides the control of the PCV direct from the machine control without interface electronics.

#### MOOG DDV PCV features the following advantages:

- Direct drive with high force level permanent magnet linear motor for high reliability
- No pilot stage oil flow
- Low hysteresis, high resolution, excellent linearity
- Pressure independent dynamic performance of servo valve
- Pressure control in mainstream and bypass function
- Standardised, accurate pressure feedback signal for monitoring
- 2 x 2 way operation extends the flow capacity in bypass mode
- At loss of supply voltage, the valve returns to its spring centered safe position and connects ports A with T or P with A.
- Improved false polarity protection and over voltage protection
- IP 65 (DIN 40050) degree of protection

Our quality management system is certified in accordance with DIN EN ISO 9001.



This catalogue is for users with technical knowledge. To ensure that all necessary characteristics for function and safety of the system are

given, the user has to check the suitability of the products described here. In case of doubt please contact MOOG.

# Series D635

## Operation

### Pressure Control function

The actual pressure in port A is measured by a pressure transducer and the output signal is conditioned and compared with the pressure command signal. If there is an error between pressure command signal and actual pressure value, the pressure controller changes current to the linear motor in such a way that the error becomes zero.

The pressure command signal can be directed via a ramp circuit with 20 s ramp up / ramp down time or direct to the comparison point (see block diagram page 3).

### Valve Flow function

The valve flow function is a sub function within the pressure control valve and not controllable externally. With zero current through the li-

near motor, the output force is zero and the centering spring moves the spool to its neutral position, where port A is connected to port T, and port P to B. Port B is normally blanked off. This position is defined as fail safe, (e.g. at loss of supply voltage).

As the motor current increases, the flow paths A → T and P → B start to close and eventually are fully closed. For

the 2 x 2 way version (valve in bypass) this is the case at 90 % and for the 3 - way version at approx. 50 % of total spool stroke (see flow functions page 4).

Further increasing of the current through the linear motor in the 3-way version causes the flow paths to open again to their max. opening for max. valve flow Q ( $Q_N$  at  $\Delta p_N$ ).

### Valve Flow and Pressure Drop

At maximum valve opening, the valve flow at rated valve pressure drop,  $\Delta p_N = 5$  bar per metering land, is rated flow,  $Q_N$  per land. For other than rated pressure drop, the valve flow changes at constant valve opening according to the following function for a sharp edged orifice (metering land).

The valve flow Q calculated in this way should result in an average flow velocity in ports P, A, B or T of no more than 30 m/s.

$$Q = Q_N \sqrt{\frac{\Delta p}{\Delta p_N}}$$

Q	[l/min]	=	calculated flow per land at $\Delta p$
$Q_N$	[l/min]	=	rated flow per land at $\Delta p_N$
$\Delta p$	[bar]	=	actual valve pressure drop per land
$\Delta p_N$	[bar]	=	rated valve pressure drop per land

### Principle of Permanent magnet linear motor operation

The linear motor is a permanent magnet excited differential motor. The permanent magnets provide a part of the required magnet force. For a linear motor, the current needed is considerably lower than would be required for a comparable proportional solenoid.

The spool driving linear motor has a neutral position at zero coil current given by the

centering spring. The spool driving force is proportional to coil current and moving the spool against the centering spring. The linear motor needs no current in the spring centered (neutral) position. The high spool driving force ensures a reliable spool movement against flow and friction forces. This makes the valve very insensitive to contamination.

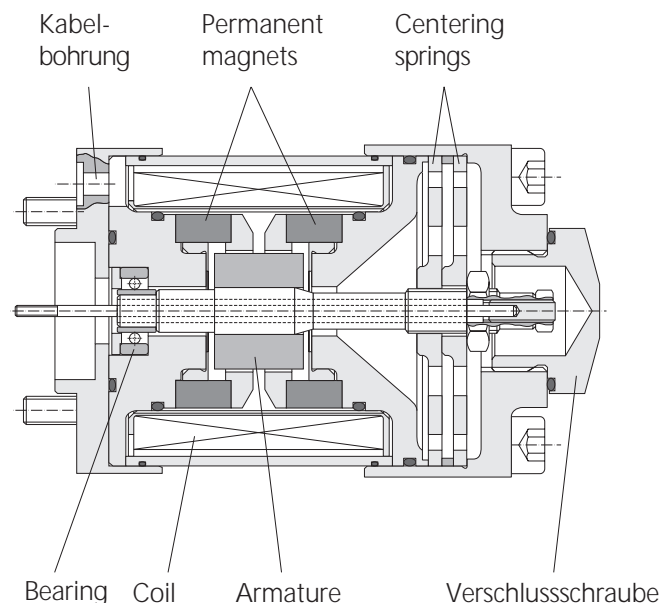

Block Diagram

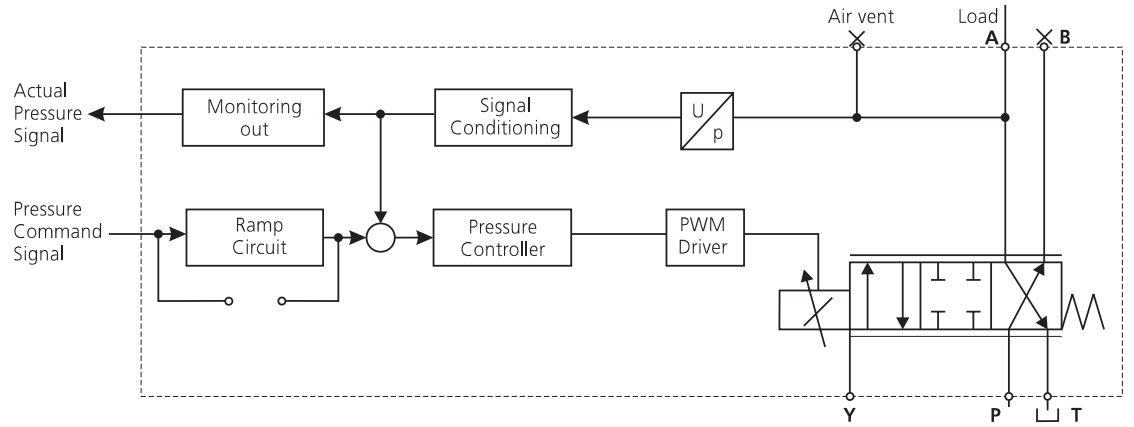

Hydraulic Symbols

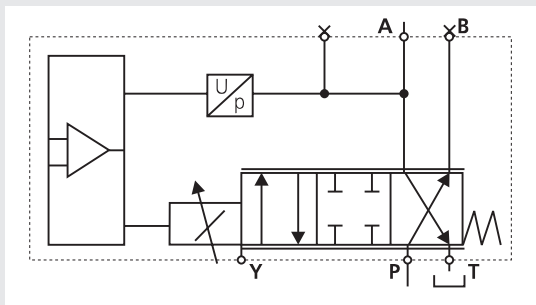

3 - Way - Function

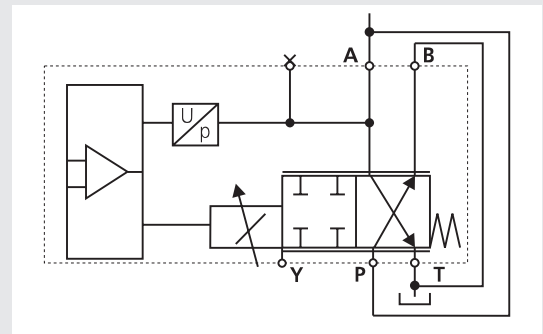

2 x 2 - Way - Function

Sectional View

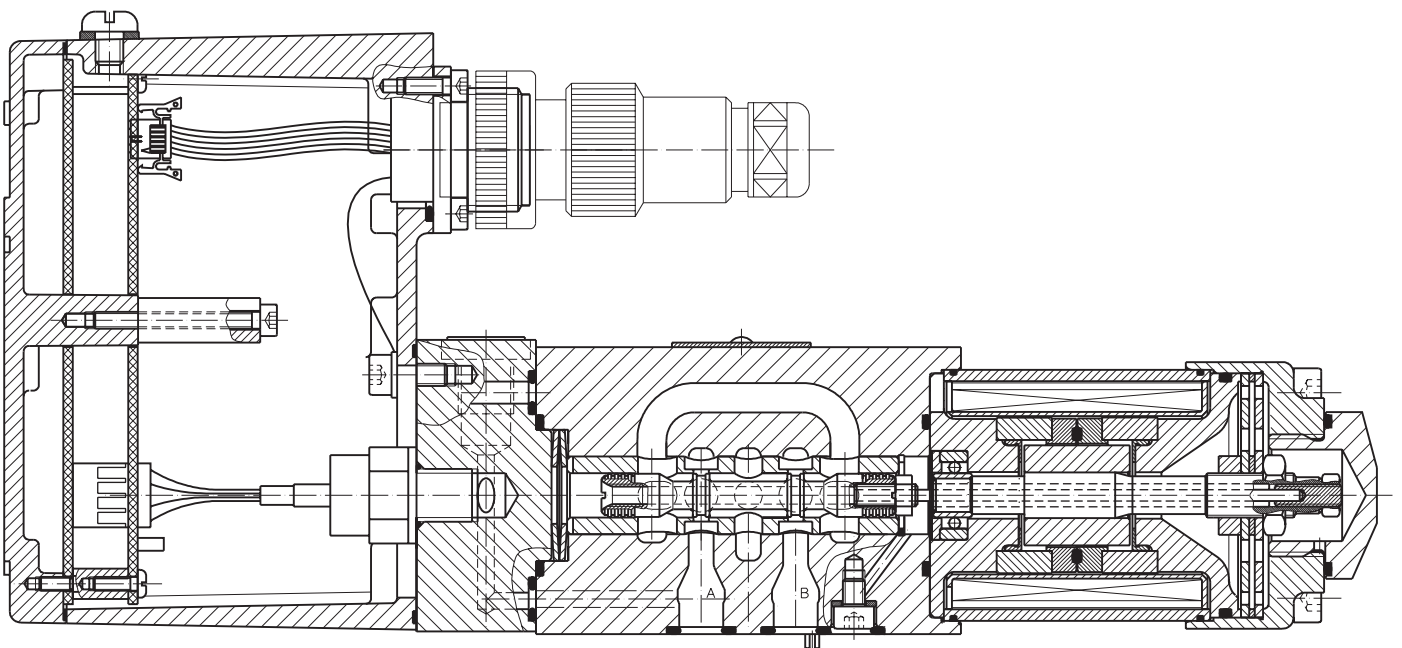

Typical Characteristic Curves

Flow Function  
at  $\Delta p_N = 35 \text{ bar per land}$

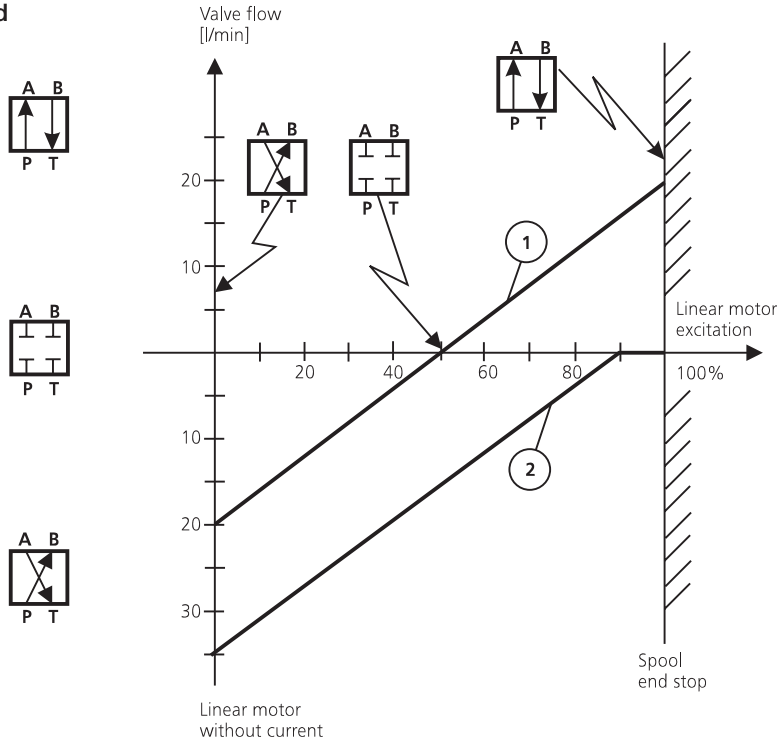

3 - Way function

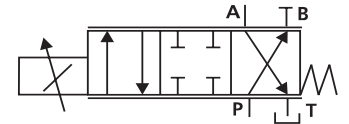

Example ①:

Symmetric flow characteristic with  $Q_N = 20 \text{ l/min}$

2 x 2 - Way function

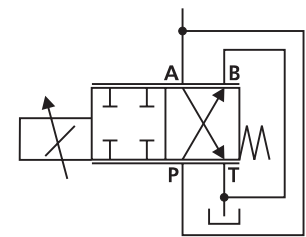

Example ②:

By-pass flow characteristic (standard) with  $Q_N = 36 \text{ l/min per land}$   
Double flow:  $2 \times Q_N = 72 \text{ l/min}$

Pressure control function  
Pressure in port A

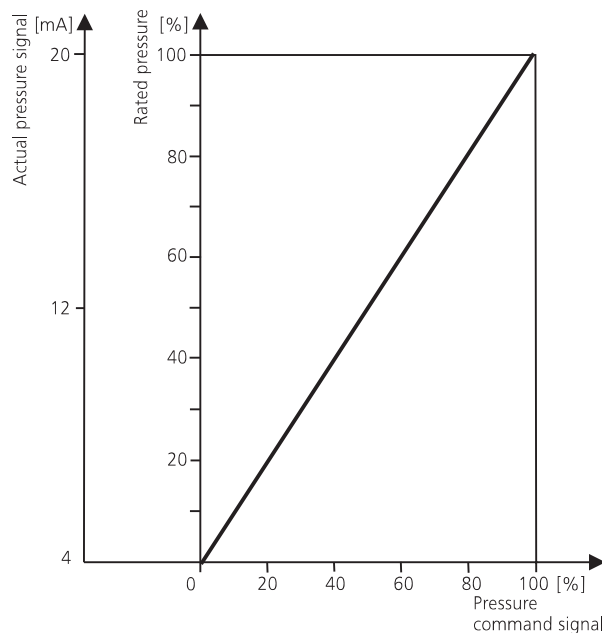

Application note

The pressure controller needs to be adapted to the load to optimise dynamic performance.

The load is mainly influenced by:  
valve rated flow  $Q_N$ , actual valve pressure drop per land  $\Delta p$ , fluid volume to be controlled connected to port A, mechanical load stiffness etc.

Contact our application engineers for assistance.

Valve design	Spool type, single stage with bushing
Actuation	Direct with permanent magnet linear motor
Mounting pattern DIN 24340 / ISO 4401 / Cetop	Form A6 / Cetop 3 with or without leakage port Y <sup>2)</sup>
Port diameter P, A, B, T	7,9 mm
Pilot supply	none
Mounting direction	any (air vent of valve must be possible)
Seal material	NBR, FPM
Degree of protection DIN 40050, with mating connector	IP 65
Mass	2,5 kg
Rated flow $Q_N$	2,5 / 5 / 10 / 20 / 40 (at 3-way function)
at $\Delta p_N = 35$ bar per land, tolerance $\pm 10$ %	4,5 / 9 / 18 / 36 (at 2-way function)
	2 x 36 (at 2 x 2 way function)
Null leakage flow $Q_L$ <sup>1)</sup>	0,15 / 0,3 / 0,6 / 1,2 l/min
max. Operating pressure $p_{max}$ static	
ports P, A, B	350 bar
port T without Y	50 bar
port T with Y	350 bar
port Y	direct to tank
Mating connector standard (DIN 43563)	6 + PE
Supply voltage for integrated electronics $U_{nom}$	+ 24 V DC
Tolerance range	+ 19 V DC
$U_{min}$	+ 32 V DC
$U_{max}$	
Current consumption at $U_{nom} = + 24$ V DC	
$I_{min}$ at pressure command zero	0,150 A
(linearmotor without current)	
$I_{max}$	1 A
Pressure command signals	0 to 10 V, 0 to 10 mA, 4 to 20 mA
Actual pressure signal	+ 4 to + 20 mA
Ramp up time = Ramp down time	20 s
Relative duty cycle	100 % ED
External fuse per valve	1,6 A T (slow blow)
Threshold <sup>1)</sup>	< 0,1 %
Hysteresis <sup>1)</sup>	< 0,2 %
Nullshift at $\Delta T = 55$ K	< 1,5 %
Linearity	< 0,5 %
Operating fluid DIN 51524	Mineral oil based hydraulic fluid, others on request
Fluid temperatur range	- 20 ... + 80 ° C
Viscosity recommended	15 ... 45 mm <sup>2</sup> /s
allowable	5 ... 400 mm <sup>2</sup> /s
Filter rating recommended	$x \leq 6$ (6 $\mu$ m absolute) <sup>3)</sup>
allowable	$x \leq 10$ (10 $\mu$ m absolute) <sup>3)</sup>
Class of cleanliness according to	6 <sup>3)</sup>
$\beta_x \geq 75$	15 / 11 <sup>3)</sup>
NAS 1638 at least	
ISO 4406 at least	
System filter	High pressure filter, mounted in the main flow without bypass, but with contamination indicator

1) measured at  $p_p = 140$  bar pressure and viscosity of  $\nu = 32$  mm<sup>2</sup>/s

2) leakage port Y must be used at  $p_T > 50$  bar

3) for long life wear protection of metering lands



D635



Specification status	
-	Series-Specification
E	Preseries-Specification
Z	Special-Specification

Model designation	
	assigned at the factory

Factory identification	

Valve version	
P	Proportional valve

Rated flow		
	$Q_N$ (l/min) at $\Delta p_N$ per land	
	5 bar	35 bar
01	1	2,5
02	2	5
04	4	10
08	8	20
16	16	40

Pressure ranges		
	Rated pressure	max. operating pressure
C	100	100
F	210	250
J	315	400
K	350	400
X	Special range on request	

Bushing / spool type	
B	3 way: P $\blacktriangleright$ A, A $\blacktriangleright$ T: ~ Axis cut, linear characteristic
Z	2 x 2 way: P $\blacktriangleright$ B, A $\blacktriangleright$ T: 10 % overlap, linear characteristic (only bypass)
X	Special version on request

Valve type	
	Pressure control without ramp
B	Valve in by-pass
M	Valve in main stream
	Pressure control with ramp
P	Valve in by-pass
R	Valve in main stream

Electrical supply	
2	+ 24 VDC (19 to 32 VDC)

Signals for pressure control		
	Command	Output
M	0 to 10 V	+4 to +20 mA
P	0 to 10 mA	+4 to +20 mA
S	+4 to +20 mA	+4 to +20 mA

Valve connector	
S	6 + PE-pole DIN 43563

Seal material	
N	NBR (Buna N) Standard version
V	FPM (Viton) Special version others on request

Y - Port		
0	Closed with plug	$p_{Tmax} = 50$ bar
1	Open, with filter insert	$p_T > 50$ bar

Spool position without electrical supply	
A	defined end position A $\blacktriangleright$ T connected
B	defined end position P $\blacktriangleright$ A connected

Linear motor	
1	Standard

All combinations may not be available. Options may increase price. Technical changes are reserved.

# MOOG



<b>Australia</b>	Melourne
<b>Austria</b>	Vienna
<b>Brazil</b>	São Paulo
<b>Denmark</b>	Birkerød
<b>England</b>	Tewkesbury
<b>Finland</b>	Espoo
<b>France</b>	Rungis

This catalogue is for users with some basic technical knowledge. To ensure that all necessary characteristics for function and safety of the system are considered, the user is cautioned to check the suitability of the products.

If there are questions or concerns, please contact MOOG.

<b>Germany</b>	Böblingen
<b>Hong Kong</b>	Kwai Chung
<b>India</b>	Bangalore
<b>Ireland</b>	Ringaskiddy
<b>Italy</b>	Malnate(VA)
<b>Japan</b>	Hiratsuka
<b>Korea</b>	Kwangju
<b>Philippines</b>	Baguio
<b>Russia</b>	Pavlovo
<b>Singapore</b>	Singapore
<b>Spain</b>	Orio
<b>Sweden</b>	Gothenburg
<b>USA</b>	East Aurora (NY)

MOOG Controls Limited  
Ashchurch  
Tewkesbury  
Gloucestershire  
GL20 8NA  
Telephone (0684) 29 66 00  
Telefax (0684) 29 67 60

MOOG GmbH  
Hanns-Klemm-Straße 28  
D - 71034 Böblingen  
Postfach 1670  
D - 71006 Böblingen  
Telefon (07031) 622-0  
Telefax (07031) 622-191

D 635 E / Rev. 3 / 08.99